



## 23 Technical Information



### Table of Contents

Technical Information	Page No.
<b>Conductors</b>	<b>23.2 – 23.5</b>
Table 1: Solid Copper Wire, American Wire Gage	23.2
Table 2: Stranded Copper Wire, American Wire Gage	23.3
Table 3: Current Ratings for Belden Electronic Cables	23.4
Table 4: Metric/Imperial/Circular Mills/AWG Equivalents	23.5
<b>Insulations and Jackets</b>	<b>23.6 – 23.11</b>
Insulations and Jackets: Overview	23.6
Characteristics of Popular Insulation and Jacket Compounds	23.7
Table 5: Comparative Properties of Plastic Compounds	23.8
Table 6: Comparative Properties of Fluoropolymer	23.9
Table 7: Comparative Properties of Rubber Insulations	23.10
Table 8: Nominal Temperature Ranges	23.11
<b>Shielding and Armoring</b>	<b>23.12 – 23.14</b>
Shielding: Overview	23.12
Characteristics of Belden Shield Types and Armor Styles	23.13
Foil Shields	23.13
Braid Shields	23.13
Spiral/Serve Shields	23.13
“French Braid” Shields	23.13
Combination Shields	23.13
Shield Types: Application Guide	23.14
Table 9: Relative Cost Comparison of Shield Types	23.14
Table 10: Shield Performance Comparison	23.14
Armoring: Overview	23.14
<b>Metric Conversions</b>	<b>23.15 – 23.16</b>
Table 11: Temperature Conversions	23.15
Table 12: Distance and Weight Conversion Formulas	23.15
Table 13: RG Types	23.15
Table 14: Conductor Size Equivalents	23.16
<b>Belden Color Code Charts</b>	<b>23.17 – 23.19</b>
<b>Halogen-Free Standards: Overview</b>	<b>23.20</b>
<b>Environmental Regulations and Compliance</b>	<b>23.21</b>
<b>Cable Packaging</b>	<b>23.22</b>
<b>Terms of Use</b>	<b>23.22</b>

The information, graphs, tables and illustrations presented in this section are provided to assist Belden customers with the selection of the most appropriate cable for their application. For further assistance, contact Belden technical support at: +31-77-3875-414.

## Conductor

Table 1: Solid Copper Wire, American Wire Gage

Gage (AWG)	Nominal OD			Nominal Circular MIL Area	Nominal Weight		Nominal Resistance @ 68°F (20°C)	
	inch	mm	mm <sup>2</sup>		lbs./1000 ft.	kg/km	Ω/1000 ft.	Ω/km
40	0.0031	0.079	0.005	9.61	0.02993	0.04	1080.0	3542.40
39	0.0035	0.089	0.006	12.20	0.03774	0.06	847.8	2780.78
38	0.0040	0.102	0.008	15.72	0.04759	0.07	648.6	2127.41
37	0.0045	0.114	0.010	19.83	0.0613	0.09	512.1	1679.69
36	0.0050	0.127	0.013	25.00	0.07568	0.11	414.8	1360.54
35	0.0056	0.142	0.016	31.52	0.09542	0.14	331.0	1085.68
34	0.0063	0.160	0.020	39.75	0.1203	0.18	260.9	855.75
33	0.0071	0.180	0.025	50.13	0.1517	0.23	206.9	678.63
32	0.0080	0.203	0.032	63.21	0.1913	0.28	164.1	538.25
31	0.0089	0.226	0.040	79.7	0.2413	0.36	130.1	426.73
30	0.0100	0.254	0.051	100.5	0.3042	0.45	103.2	338.50
29	0.0113	0.287	0.064	126.7	0.3836	0.57	81.83	268.40
28	0.0126	0.320	0.080	159.8	0.4837	0.72	64.90	212.87
27	0.0142	0.361	0.102	201.5	0.6100	0.91	51.47	168.82
26	0.0159	0.404	0.127	253.0	0.7692	1.14	40.81	133.86
25	0.0179	0.455	0.163	320.4	0.9699	1.44	32.37	106.17
24	0.0201	0.511	0.203	404.0	1.223	1.82	25.67	84.20
23	0.0226	0.574	0.259	511.5	1.542	2.29	20.36	66.78
22	0.0253	0.643	0.322	640.4	1.945	2.89	16.14	52.94
21	0.0285	0.724	0.412	812.1	2.452	3.65	12.80	41.98
20	0.0320	0.813	0.514	1020.0	3.092	4.60	10.15	33.29
19	0.0359	0.912	0.653	1200.0	3.899	5.80	8.051	26.41
18	0.0403	1.02	0.816	1620.0	4.917	7.32	6.385	20.94
17	0.0453	1.15	1.039	2050.0	6.200	9.22	5.064	16.61
16	0.0508	1.29	1.300	2583.0	7.818	11.63	4.016	13.17
15	0.0571	1.45	1.651	3260.0	9.858	14.67	3.184	10.44
14	0.0641	1.63	2.070	4107.0	12.43	18.49	2.525	8.28
13	0.0720	1.83	2.630	5178.0	15.68	23.33	2.003	6.57
12	0.0808	2.05	3.290	6530.0	19.77	29.41	1.588	5.21
11	0.0907	2.30	4.155	8234.0	24.92	37.08	1.260	4.13
10	0.1019	2.60	5.230	10380.0	31.43	46.76	0.9989	3.28

\* AWG 10 through 30 per UL Subject 13.

Information from National Bureau of Standards Copper Wire Tables – Handbook 100.

### Unparalleled Performance

Belden is one of only a very few cable manufacturers to draw and anneal its own conductors. This is a time-consuming process, but it allows us to ensure signal integrity, as well as proper physical characteristics.

In addition, the standards under which we design and manufacture our fiber optic cabling are among the strictest in the industry. The result is a comprehensive offering of products which give unparalleled performance and can satisfy your most demanding operating and environmental challenges.

**Conductor**

Table 2: Stranded Copper Wire, American Wire Gage

Gage (AWG)	Stranding (Nom. AWG)	Min. Average CD of Strand	Approximate OD			ASTM Min. Circular MIL Area	Min. Weight		Max. Resistance @ 68°F (20°C)	
			inch	mm	mm <sup>2</sup>		lbs./1000 ft.	kg/km	Ω/1000 ft.	Ω/km
36	7x44	0.0019	0.006	0.152	0.014	25	0.076	0.11	414.8	1360.54
34	7x42	0.0024	0.0075	0.191	0.022	39.7	0.121	0.18	260.9	855.75
32	7x40	0.0030	0.0093	0.236	0.034	64	0.195	0.29	164.1	538.25
	19x44	0.0018	0.010	0.254	0.039	64	0.195	0.29	164.1	538.25
30	7x38	0.0038	0.012	0.305	0.056	100	0.304	0.45	112.0	367.36
	19x42	0.0023	0.012	0.305	0.060	100	0.304	0.45	112.0	367.36
28	7x36	0.0048	0.015	0.381	0.071	159	0.484	0.72	70.7	231.90
	19x40	0.0029	0.016	0.406	0.093	159	0.484	0.72	70.7	231.90
27	7x35	0.0054	0.017	0.432	0.111	202	0.614	0.91	55.6	182.37
26	7x34	0.0060	0.019	0.483	0.140	253	0.770	1.15	44.4	145.63
	10x36	0.0050	0.021	0.533	0.127	253	0.770	1.15	44.4	145.63
	19x38	0.0036	0.020	0.508	0.153	253	0.770	1.15	44.4	145.63
24	7x32	0.0076	0.024	0.610	0.226	404	1.229	1.83	27.7	90.86
	10x34	0.0064	0.024	0.610	0.200	404	1.229	1.83	27.7	90.86
	19x36	0.0046	0.024	0.610	0.239	404	1.229	1.83	27.7	90.86
	42x40	0.0031	0.023	0.584	0.201	404	1.229	1.83	27.7	90.86
22	7x30	0.0096	0.030	0.762	0.352	640	1.947	2.90	17.5	57.40
	19x34	0.0058	0.031	0.787	0.380	640	1.947	2.90	17.5	57.40
	26x36	0.0050	0.030	0.762	0.327	640	1.947	2.90	17.5	57.40
20	7x28	0.0126	0.038	0.965	–	1020	3.103	4.62	10.9	35.75
	10x30	0.0101	0.037	0.940	0.612	1020	3.103	4.62	10.9	35.75
	19x32	0.0073	0.037	0.940	0.612	1020	3.103	4.62	10.9	35.75
	26x34	0.0063	0.036	0.914	0.520	1020	3.103	4.62	10.9	35.75
	42x36	0.0049	0.038	0.965	–	1020	3.103	4.62	10.9	35.75
18	7x26	0.0152	0.048	1.22	0.891	1620	4.93	7.33	6.92	22.70
	16x30	0.0101	0.047	1.19	0.808	1620	4.93	7.33	6.92	22.70
	19x30	0.0092	0.049	1.24	0.957	1620	4.93	7.33	6.92	22.70
	42x34	0.0062	0.047	1.19	0.819	1620	4.93	7.33	6.92	22.70
	65x36	0.0050	0.047	1.19	–	1620	4.93	7.33	6.92	22.70
16	7x24	0.0192	0.060	1.52	1.420	2580	7.85	11.68	4.35	14.27
	19x29	0.0117	0.058	1.47	1.216	2580	7.85	11.68	4.35	14.27
	26x30	0.0100	0.059	1.50	1.310	2580	7.85	11.68	4.35	14.27
	65x34	0.0063	0.059	1.50	1.300	2580	7.85	11.68	4.35	14.27
	105x36	0.0050	0.059	1.50	1.365	2580	7.85	11.68	4.35	14.27
14	7x22	0.0242	0.076	1.93	–	4110	12.50	18.60	2.73	8.95
	19x26	0.0147	0.071	1.80	–	4110	12.50	18.60	2.73	8.95
	42x30	0.0099	0.075	1.91	–	4110	12.50	18.60	2.73	8.95
	105x34	0.0063	0.075	1.91	–	4110	12.50	18.60	2.73	8.95
12	7x20	0.0305	0.096	2.44	3.610	6530	19.86	29.55	1.71	5.61
	19x25	0.0185	0.093	2.36	3.070	6530	19.86	29.55	1.71	5.61
	65x30	0.0100	0.095	2.41	3.270	6530	19.86	29.55	1.71	5.61
	165x34	0.0063	0.095	2.41	3.300	6530	19.86	29.55	1.71	5.61
10	37x26	0.0167	0.115	2.92	4.710	10380	31.58	46.98	1.08	3.54
	65x28	0.0126	0.120	3.05	–	10380	31.58	46.98	1.08	3.54
	105x30	0.0099	0.118	3.00	–	10380	31.58	46.98	1.08	3.54

\* AWG 10 through 30 per UL subject 13.

Belden has standardized on the stranded conductors used in the design of all Belden products.

## Conductor

Table 3: Current Ratings for Belden Electronic Cables

The maximum continuous current rating for an electronic cable is limited by conductor size, number of conductors contained within the cable, maximum temperature rating of the cable, and environmental conditions such as ambient temperature and air flow. To use the current capacity chart, first determine conductor size, temperature rating, and number of conductors from the applicable product description for the cable of interest.

Next, find the current value on the chart for the proper temperature rating and conductor size. To calculate the maximum current rating/conductor, multiply the chart value by the appropriate conductor factor. The chart assumes cable is surrounded by still air at an ambient temperature of 25°C. Current values are in RMS amperes and are valid for copper conductors only. For conditions other than specified, contact Belden technical support at +31-77-3875-414.

Note: Current ratings are intended as general guidelines for low power electronic communications and control applications. Current ratings for power applications generally are set by regulatory agencies such as UL, CSA, NEC, and others.

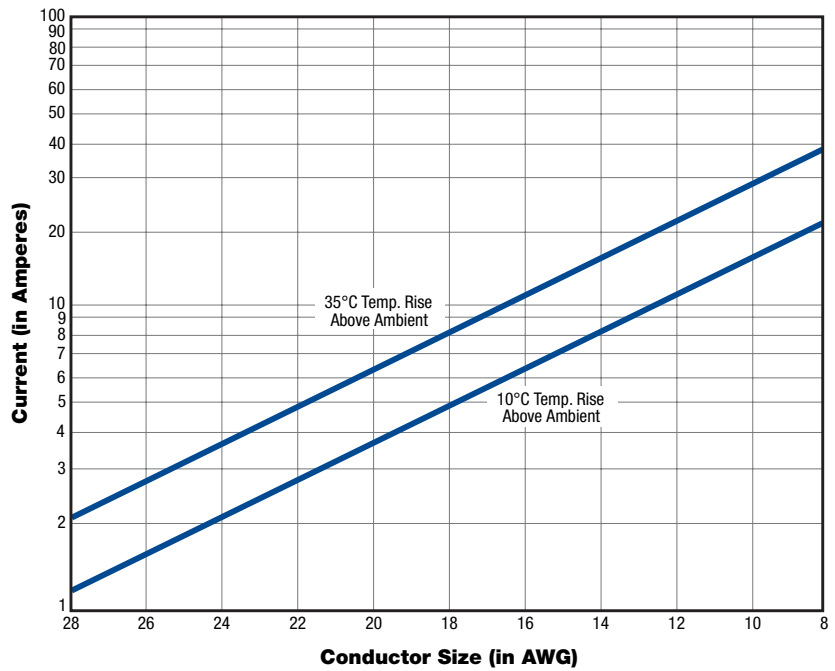

### Current Rating

No. of Conductors*	Factor
1	1.6
2 to 3	1.0
4 to 5	0.8
6 to 15	0.7
16 to 30	0.5

\* Do not count shields unless used as conductor.

### Conductor

Table 4: Metric/Imperial/AWG Equivalents  
(Square Millimeters/Square Inches/Circular Mils/AWG)

mm <sup>2</sup>	sq. in.	Circular mils	AWG	mm <sup>2</sup>	sq. in.	Circular mils	AWG	mm <sup>2</sup>	sq. in.	Circular mils	AWG
1000	1.550	1974000		55	0.0853	108570		5.00	0.00775	9870	
975	1.511	1924700		—	—	105600	1/0	4.75	0.00736	9377	
950	1.472	1875300		50	0.0775	98700		4.50	0.00698	8883	
925	1.434	1826000		45	0.0698	88830		4.25	0.00659	8390	
900	1.395	1776600		—	—	83690	1	—	—	8230	11
875	1.356	1727300		40	0.0620	78960		4.00	0.00620	7896	
850	1.317	1677900		35	0.0542	69090		3.75	0.00581	7403	
825	1.279	1628600		—	—	66360	2	3.50	0.00542	6909	
800	1.240	1579200		30	0.0465	59220		—	—	6530	12
775	1.201	1529900		—	—	52620	3	3.25	0.00504	6416	
750	1.163	1480500		25	0.0388	49350		3.00	0.00465	5922	
725	1.124	1431200		—	—	41740	4	2.75	0.00426	5429	
700	1.085	1381800		20.0	0.0310	39480		2.63	—	5180	13
675	1.046	1332500		19.5	0.0302	38490		2.50	0.00388	4935	
650	1.008	1283100		19.0	0.0294	37510		2.25	0.00349	4422	
625	0.969	1233800		18.5	0.0287	36520		—	—	4110	14
600	0.930	1184400		18.0	0.0279	35530		2.00	0.00310	3948	
575	0.891	1135100		17.5	0.0271	34550		1.75	0.00271	3455	
550	0.853	1085700	1000 MCM	17.0	0.0264	33560		1.65	—	3260	15
525	0.814	1036400		—	—	33090	5	1.50	0.00233	2961	
500	0.775	987000		16.5	0.0256	32560		—	—	2580	16
475	0.736	937700		16.0	0.0248	31580		1.25	0.00194	2468	
450	0.698	888300		15.5	0.0240	30600	6	—	—	2050	17
425	0.659	839000		15.0	0.0233	29610		1.00	0.00155	1974	
400	0.620	789600	750 MCM	14.5	0.0225	28620		0.90	0.00140	1777	
375	0.581	740300		14.0	0.0217	27640		—	—	1620	18
350	0.542	690900		13.5	0.0209	26650		0.75	0.00116	1481	
325	0.504	641600	600 MCM	—	—	26420		0.70	0.00109	1382	
300	0.465	592200		13.0	0.0201	25660		0.65	—	1290	19
275	0.426	542900	500 MCM	12.5	0.0194	24680		0.60	0.00093	1184	
250	0.388	493500		12.0	0.0186	23690		—	—	1029	20
225	0.349	444200	350 MCM	11.5	0.0178	22700		0.50	0.000775	987	
200	0.310	394800		11.0	0.0171	21710					
185	—	—		—	—	20820	7				
175	0.271	345500	300 MCM	10.5	0.0163	20730					
150	0.233	296100		10.0	0.0155	19740					
125	0.1938	246800		9.5	0.01472	18753					
120	—	211600	4/0	9.0	0.01395	17766					
100	0.1550	197400		8.5	0.01317	16779					
95	0.1472	187530		—	—	16510	8				
90	0.1395	177660		8.0	0.01240	15792					
—	—	167800	3/0	7.7	0.01163	14805					
85	0.1317	167790		7.0	0.01085	13818					
80	0.1240	157920		—	—	13090	9				
75	0.1163	148050		6.5	0.01008	12831					
70	0.1085	138180		6.0	0.00930	11844					
—	—	133100	2/0	5.5	0.00853	10857					
65	0.1008	128310		—	—	10380	10				
60	0.0930	118440									

To Convert:	Multiply by:
Inches to millimeters	25.4
Millimeters to inches	0.03937

## Insulations and Jackets

### Overview

#### Insulations

Belden expends a great amount of time and effort to formulate its own insulations. As a result, Belden insulations provide superior performance under a variety of hostile environmental conditions.

Among the insulations we utilize are:

- **Polyethylene**
- **Polyvinyl Chloride (PVC)**
- **Polypropylene**

Also available are:

- **Datalene®**  
For computer and data transmission. Datalene is crush resistant, lightweight, and offers good performance characteristics over a wide range of temperatures.
- **Teflon® Insulated Plenum & High-temperature Cables**  
For data communications, instrumentation/control, and other commercial and industrial applications. Plenum cables eliminate the need for conduit and reduce installation time.

#### Jackets

Belden electronic cables are manufactured in a wide selection of jacketing materials.

- **Polyvinyl Chloride**
- **Polyethylene**
- **Polyurethane**
- **Teflon®**
- **Tefzel®**
- **Neoprene**
- **EPDM**
- **Silicone rubber**
- **Natural rubber**

Special compounds and variations of standard compounds are used as well.

Teflon® and Tefzel® are DuPont trademarks.

## Insulations and Jackets

### Typical Characteristics of Popular Insulation and Jacketing Compounds

#### EPDM

EPDM (ethylene-propylene-diene elastomer) is a chemically cross-linked elastomer with excellent flexibility at low and high temperatures (-55°C to 150°). It has good insulation resistance and dielectric strength, as well as excellent abrasion resistance and mechanical properties. EPDM also has better cut-through resistance than silicone rubber, which it replaces in some applications.

EPDM is compatible with most varnishes, but after the dip and bake cycle varnish tends to adhere to the insulation (because EPDM, unlike some rubber insulations, does not exude oils or waxes). As lead wires are pulled apart for termination, the varnish cracks, sometimes breaking the insulation.

To resolve this problem, a stearic solution is applied to the lead wire during the put-up process. This ensures that rigid varnish does not cause EPDM insulation to rupture when the wire is terminated.

Field evaluations by numerous users reveal that the coated EPDM has excellent varnish resistance at least equal to synthetic elastomers, cross-link polyethylene, or silicone glass braid in dip and bake systems.

#### Neoprene

The temperature range of this material can vary from -55°C to 90°C. The actual range would depend on the formulation used. Neoprene is both oil-resistant and sunlight-resistant, making it ideal for many outdoor applications. The most stable colors are Black, Dark Brown, and Gray. The electrical properties are not as good as other insulation materials. Because of this, thicker insulation should be used. Typical designs where this material is used are lead wire insulation and cable jackets.

#### Polyethylene (Solid and Foamed)

A very good insulation in terms of electrical properties. Low dielectric constant, a stable dielectric constant over all frequencies, very high insulation resistance. In terms of flexibility, polyethylene can be rated stiff to very hard, depending on molecular weight and density – low density being the most flexible, with high-density, high-molecular weight formulation being very hard. Moisture resistance is rated excellent. Black and specially formulated colored versions have excellent weather resistance. The dielectric constant is 2.3 for solid insulation and typically 1.64 for foam designs. Flame retardant formulations are available with dielectric constants ranging from about 1.7 for foam flame retardant to 2.58 for solid flame retardant polyethylene.

#### Polypropylene (Solid and Foam)

Similar in electrical properties to polyethylene. This material is primarily used as an insulation material. Typically, it is harder than polyethylene. This makes it suitable for thin wall insulations. UL maximum temperature rating may be 60°C, 80°C or 105°C. The dielectric constant is 2.25 for solid and typically 1.55 for foam designs.

#### Polyurethane

This material is used primarily as a cable jacket material. It has excellent oxidation, oil, and ozone resistance. Some formulations also have good flame resistance. It is a hard material with excellent abrasion resistance. It has outstanding “memory” properties, making it an ideal jacket material for retractile cords.

#### PVC

Sometimes referred to as vinyl or polyvinylchloride. Extremely high or low temperature properties cannot be found in one formulation. Certain formulations may have -55°C to 105°C rating. Other common vinyls may have -20°C to 60°C. There are many formulations for the variety of different applications. The many varieties of PVC also differ in pliability and electrical properties. The price range can vary accordingly. Typical dielectric constant values can vary from 3.5 to 6.5.

#### Rubber

The description of rubber normally includes natural rubber and SBR compounds. Both of these materials can be used for insulations and jackets. There are many formulations of these basic materials. Each formulation is for a specific application. Some formulations are suitable for -55°C minimum, while others are suitable for 75°C maximum.

#### Silicone

This is a very soft insulation which has a temperature range from -80°C to 200°C. It has excellent electrical properties plus ozone resistance, low moisture absorption, weather resistance, and radiation resistance. It typically has low mechanical strength and poor scuff resistance.

#### Teflon®

This material has excellent electrical properties, temperature range and chemical resistance. It is not suitable where subjected to nuclear radiation and does not have good high voltage characteristics. FEP Teflon® is extrudable in a manner similar to PVC and polyethylene. This means that long wire and cable lengths are available. TFE Teflon® is extrudable in a hydraulic ram type process. Lengths are limited due to amount of material in the ram, thickness of the insulation, and preform size. TFE must be extruded over a silver- or nickel-coated wire. The nickel- and silver-coated designs are rated 260°C and 200°C maximum, respectively. The cost of Teflon® is approximately 8 to 10 times more per weight unit than that of PVC.

Teflon® is a DuPont trademark.

## Insulations and Jackets

Table 5: Comparative Properties of **Plastic** Insulating and Jacketing Compounds

Properties	PVC	LDPE	Cellular Polyethylene	HDPE	Polypropylene	Cellular Polypropylene	PUR	Nylon	CPE	LSNH	FEP Teflon®
<b>Oxidation Resistance</b>	E	E	E	E	E	E	E	E	E	E	O
<b>Heat Resistance</b>	G-E	G	G	E	E	E	G	E	E	G-E	O
<b>Oil Resistance</b>	F	G-E	G	G-E	F	F	E	E	E	G	E
<b>Low-temperature Flexibility</b>	P-G	E	E	E	P	P	G	G	E	F-G	O
<b>Weather, Sun Resistance</b>	G-E	E	E	E	E	E	G	E	E	G	O
<b>Ozone Resistance</b>	E	E	E	E	E	E	E	E	E	E	E
<b>Abrasion Resistance</b>	F-G	G	F	E	F-G	F-G	O	E	E-O	F-G	E
<b>Electrical Properties</b>	F-G	E	E	E	E	E	P	P	E	G	E
<b>Flame Resistance</b>	E	P	P	P	P	P	P	P	E	E	E
<b>Nuclear Radiation Resistance</b>	F	G-E	G	G-E	F	F	G	F-G	O	F	P
<b>Water Resistance</b>	F-G	E	E	E	E	E	P-G	P-F	O	G	E
<b>Acid Resistance</b>	G-E	G-E	G-E	E	E	E	F	P-F	E	P-F	E
<b>Alkali Resistance</b>	G-E	G-E	G-E	E	E	E	F	E	E	G	E
<b>Aliphatic Hydrocarbons Resistance</b> (Gasoline, Kerosene, etc.)	P	G-E	G	G-E	P-F	P	P-G	G	E	F	E
<b>Aromatic Hydrocarbons Resistance</b> (Benzol, Toluol, etc.)	P-F	P	P	P	P-F	P	P-G	G	G-E	P-F	E
<b>Halogenated Hydrocarbons Resistance</b> (Degreaser Solvents)	P-F	G	G	G	P	P	P-G	G	E	P	E
<b>Alcohol Resistance</b>	P-F	E	E	E	E	E	P-G	P	E	G	E
<b>Underground Burial</b>	P-G	G	N/A	E	N/A	N/A	G	P	E-O	F	E

CPE = Chlorinated Polyethylene • HDPE = High-density Polyethylene • LDPE = Low-density Polyethylene • PUR = Polyurethane • LSNH = Low-smoke Non-halogen • FEP = Fluorinated Ethylene-Propylene • P = Poor • F = Fair • G = Good • E = Excellent • O = Outstanding

These ratings are based on average performance of general purpose compounds. Any given property can usually be improved by the use of selective compounding.

Teflon® is a DuPont trademark.

## Insulations and Jackets

Table 6: Comparative Properties of **Fluoropolymer** Insulating and Jacketing Compounds

Properties	FEP Teflon®	Tefzel® (ETFE)	PTFE Teflon®
<b>Oxidation Resistance</b>	O	E	O
<b>Heat Resistance</b>	O	E	O
<b>Oil Resistance</b>	O	E	E-O
<b>Low-temperature Flexibility</b>	O	E	O
<b>Weather, Sun Resistance</b>	O	E	O
<b>Ozone Resistance</b>	E	E	O
<b>Abrasion Resistance</b>	E	E	O
<b>Electrical Properties</b>	E	E	E
<b>Flame Resistance</b>	O	G	E
<b>Nuclear Radiation Resistance</b>	P-G	E	P
<b>Water Resistance</b>	E	E	E
<b>Acid Resistance</b>	E	E	E
<b>Alkali Resistance</b>	E	E	E
<b>Aliphatic Hydrocarbons Resistance</b> (Gasoline, Kerosene, etc.)	E	E	E
<b>Aromatic Hydrocarbons Resistance</b> (Benzol, Toluol, etc.)	E	E	E
<b>Halogenated Hydrocarbons Resistance</b> (Degreaser Solvents)	E	E	E
<b>Alcohol Resistance</b>	E	E	E
<b>Underground Burial</b>	E	E	E

FEP = Fluorinated Ethylene-Propylene • ETFE = Ethylene Tetrafluoroethylene • PTFE = Polytetrafluoroethylene  
P = Poor • F = Fair • G = Good • E = Excellent • O = Outstanding

These ratings are based on average performance of general purpose compounds.  
Any given property can usually be improved by the use of selective compounding.

Teflon® and Tefzel® are DuPont trademarks.

## Insulations and Jackets

Table 7: Comparative Properties of **Rubber** Insulations

Properties	Rubber	Neoprene	Hypalon® (Chlorosulfonated Polyethylene)	EPDM (Ethylene-Propylene- Diene Elastomer)	Silicone
<b>Oxidation Resistance</b>	F	G	E	E	E
<b>Heat Resistance</b>	F	G	E	E	O
<b>Oil-resistance</b>	P	G	G	P	F-G
<b>Low-temperature Flexibility</b>	G	F-G	F	G-E	O
<b>Weather, Sun Resistance</b>	F	G	E	E	O
<b>Ozone Resistance</b>	P	G	E	E	O
<b>Abrasion Resistance</b>	E	G-E	G	G	P
<b>Electrical Properties</b>	G	P	G	E	G
<b>Flame Resistance</b>	P	G	G	P	F-G
<b>Nuclear Radiation Resistance</b>	F	F-G	E	G	E
<b>Water Resistance</b>	G	E	E	G-E	G-E
<b>Acid Resistance</b>	F-G	G	E	G-E	F-G
<b>Alkali Resistance</b>	F-G	G	E	G-E	F-G
<b>Aliphatic Hydrocarbons Resistance</b> (Gasoline, Kerosene, etc.)	P	G	F	P	P-F
<b>Aromatic Hydrocarbons Resistance</b> (Benzol, Toluol, etc.)	P	P-F	F	F	P
<b>Halogenated Hydrocarbons Resistance</b> (Degreaser Solvents)	P	P	P-F	P	P-G
<b>Alcohol Resistance</b>	G	F	G	P	G

P = Poor • F = Fair • G = Good • E = Excellent • O = Outstanding

These ratings are based on average performance of general purpose compounds.  
Any given property can usually be improved by the use of selective compounding.

Hypalon® is a DuPont trademark.

## Insulations and Jackets

Table 8: Nominal Temperature Range for Various Insulating and Jacketing Compounds

Compound	Normal Low	Normal High	Special Low	Special High
Chlorosulfonated Polyethylene (Hypalon®)	-20°C	90°C	-40°C	105°C
EPDM (Ethylene-Propylene-Diene Monomer)	-55°C	105°C	–	150°C
Neoprene	-20°C	60°C	-55°C	90°C
Polyethylene (Solid and Foamed)	-60°C	80°C	–	–
Polypropylene (Solid and Foamed)	-40°C	105°C	–	–
Rubber	-30°C	60°C	-55°C	75°C
FEP Teflon®	-70°C	200°C	–	–
PVC	-20°C	80°C	-55°C	105°C
Silicone	-80°C	150°C	–	200°C
Tefzel®	-65°C	150°C	–	–
PTFE Teflon®	-70°C	260°C	–	–
GPE	-35°C	90°C	-45°C	105°C

Hypalon®, Teflon® and Tefzel® are DuPont trademarks.

## Shielding and Armoring

### Overview

#### Innovative Leadership

The evolution of technology maintains steady demand for sophisticated cable shielding. Belden meets that demand with innovative shielding and shield effectiveness testing methods to supply you with high quality, dependable cable.

With the creation of trademarked shield designs and patented test methods, Belden has earned a reputation for innovation and leadership that is unequalled in the wire and cable industry. In addition, Belden offers the broadest line of shielded multi-conductor, coaxial and flat cable in the industry.

Several unique Belden innovations are utilized across a wide range of shielding applications:

- Beldfoil®**  
 The first aluminum/polyester foil developed for use as a cable shield. Provides 100% shield coverage for optimum protection.
- Duofoil®**  
 Consists of an aluminum-poly-aluminum laminate wrapped around the cable's dielectric core. Provides 100% physical coverage, and improves shield reliability and flex life.

Belden also utilizes a number of innovative techniques to apply shielding to multi-conductor and paired cables:

- “French Braid” Shields**  
 Belden's patented “French Braid” shield is a double spiral (double serve shield) with the two spirals tied together by one weave.

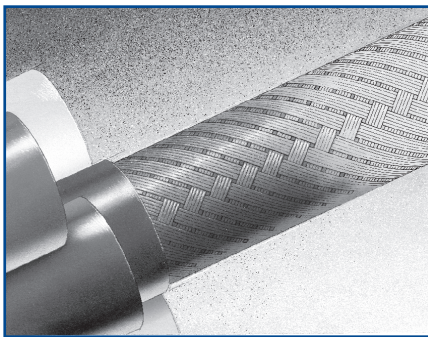

Belden's patented “French Braid” shield.

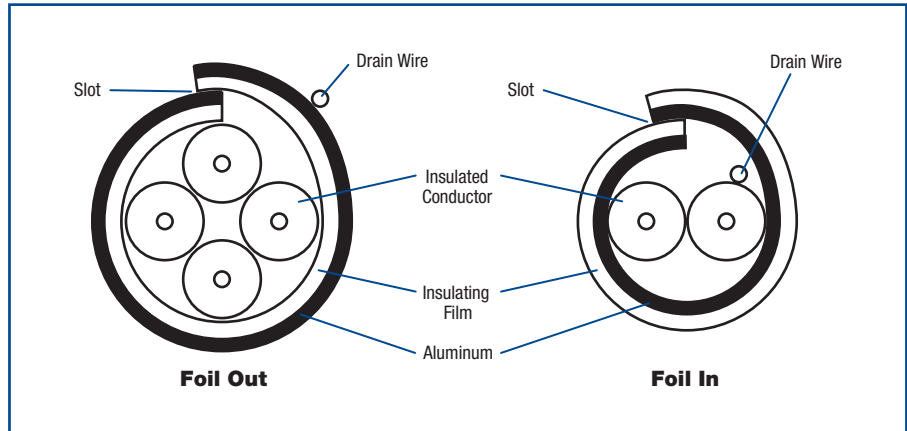

Figure 1: Foil shield configurations without shorting folds.

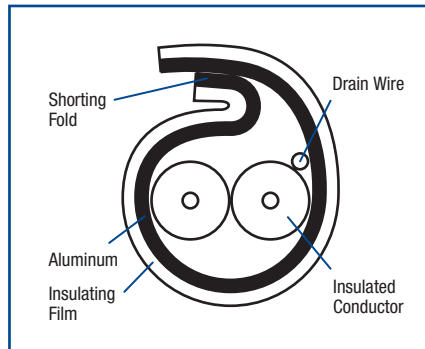

Figure 2: Foil shield configurations with shorting fold.

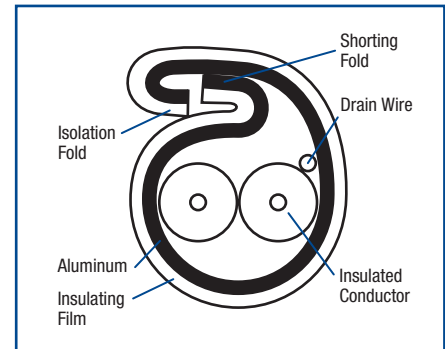

Figure 3: Foil shield with Z-fold reduces crosstalk in multi-pair applications.

- Shorting Fold**  
 Belden uses a shorting fold technique to maintain metal-to-metal contact for improved high frequency performance. Without the shorting fold, a slot is created through which signals can leak and cause interference. (See figures 1 and 2 above.)

- Z-Fold®**  
 Belden improves on the traditional shorting fold by employing a Z-Fold designed for use in multi-pair applications to reduce crosstalk. The Z-Fold (see figure 3) combines an isolation and a shorting fold. The shorting fold provides metal-to-metal contact while the isolation fold keeps shields from shorting to one another in multi-pair, individually shielded cables.

The use of either a shorting fold or a Z-Fold increases the foil shield's range of effectiveness to higher frequencies.

## Shielding and Armoring

### Characteristics of Belden Shield Types and Armor Styles

#### Foil Shields

Foil shields consist of aluminum foil laminated to a polyester or polypropylene film. The film gives the shield mechanical strength and bonus insulation. Foil shields provide 100% cable coverage, necessary for electrostatic shield protection. Because of their small size, foil shields are commonly used to shield individual pairs of multi-pair data cables to reduce crosstalk. They have less weight, bulk and cost less than spiral or braid shields and are generally more effective than braid shields in RF ranges. Foil shields are more flexible than braid but have a shorter flex life than spiral or braid.

Drain wires are used with foil shields to make termination easier and to ground electrostatic discharges. The shortcomings in using the foil shield include higher dc resistance and lower mechanical strength than braid or spiral shields.



#### Braid Shields

A braid shield consists of groups of tinned or bare copper or aluminum strands, one set woven in a clockwise direction and interwoven with another set in a counter-clockwise direction.

Braid shields provide superior structural integrity, while maintaining good flexibility and flex life. These shields are ideal for minimizing low frequency interference and have lower DC resistance than foil. Braid shields are effective at audio, as well as RF ranges. Generally, the higher the braid coverage, the more effective the shield. However, the trade-off between cost and braid coverage must be considered. Typical braid coverages are between 80% and 95%. Coverage of 100% is unattainable with a braid shield. Other features to consider when choosing a braid shield are the weave angle, strand diameter, number of carriers (strand groups) and the number of ends (strands).

Braid shields are generally bulkier and heavier than other shields and, in some cases, harder to terminate because the braid may be combed out and pigtailed.

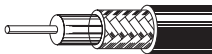

#### Spiral/Serve Shields

A spiral/serve shield consists of wire (usually copper) wrapped in a spiral around the inner cable core.

Superior flexibility and flex life, ease of termination and up to 97% coverage are the advantages of spiral shields. They are best suited for audio applications. As a rule, spiral shields are not effective above the audio frequency range due to the coil effect produced by the inductance of served wire strands.



#### “French Braid” Shields

Belden's patented “French Braid” shield is a double spiral (double serve shield) with the two spirals tied together by one weave. This construction provides improved flex life over standard spiral shields, improved flexibility over conventional braid shields, and lower levels of microphonic or triboelectric noise than either spiral or conventional braid shields.



#### Combination Shields

Combination shields consist of more than one layer of shielding. They provide maximum shield efficiency across the frequency spectrum. The combination foil/braid shield combines the advantages of 100% foil coverage, plus the strength and low DC resistance of the braid.

Belden has also developed a number of shielding configurations for use with broadband coaxial cables.

- **Duobond®**  
Duobond is essentially the same construction as Duofoil® (a laminated tape of foil/film/foil), but with an extra layer of adhesive bonding the foil shield to the dielectric core. This foil shield provides 100% coverage and insures maximum shield protection.

- **Duobond II (Foil/Braid)**

Combines Duobond with an outer braid, applied for greater protection against interference and to increase the overall tensile strength.

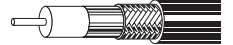

- **Duobond III (Tri-Shield)**

Utilizes the Duobond II design (foil/braid) plus a surrounding layer of Duofoil. The extra foil layer improves shield reliability and provides an additional interference barrier.



- **Duobond Plus®**

Features foil/braid/foil construction with a shorting fold in the outermost foil. This fold prevents a slot opening from being created in the shield, thereby preventing signal egress or ingress.



Shorting Fold

- **Duobond IV (Quad Shield)**

Offers an extra layer of braid shield (foil/braid/foil/braid) for improved strength and durability.



Other combination shields are available such as the foil/braid/foil/braid used on the Ethernet cables, braid/braid or foil/spiral.

#### Armoring

Belden's innovative technology delivers maximum effectiveness to meet the performance requirements of a wide range of applications.

Belden also has the capability to protect electronic, instrumentation, and control cables with interlocking steel or aluminum armor.

## Shielding and Armoring

### Shield Types Application Guide, Table 9: Relative Cost Comparison of Shield Types

### Table 10: Shield Performance Ratings

#### Shield Types Application Guide

##### Choose a Foil Shield...

- For protection against capacitive (electric field) coupling where shield coverage is more important than low DC resistance.
- When possible sources of interference include TV signals, crosstalk from other circuits, radio transmitters, fluorescent lights or computing equipment.
- For MATV, CATV, video, networking, computer I/O cables in office, industrial or commercial environments where ambient EMI levels are low.

##### Choose a Braid Shield...

- For superior performance against diffusion coupling, where low DC resistance is important, and to a lesser extent, capacitive and inductive coupling.
- When possible sources of interference exhibit low impedance characteristics, such as motor control circuits and switches which operate inductive loads.
- For computer to terminal interconnect for process, instrumentation or control applications.

##### Choose a Spiral Shield...

- For functional shielding against diffusion and capacitive coupling at audio frequencies only.
- When possible sources of interference are power lines and fluorescent lights.
- For applications when flexibility and flex life are major concerns, such as microphone and audio cables and retractile cords.

##### Choose a Combination Shield...

- For shielding against high frequency radiated emissions coupling and ESD. Combines the low resistance of braid and 100% coverage of foil shields.
- When possible sources of interference include radio transmitters, TV stations, printed circuit boards, back planes, motor control circuits and computing equipment.
- For video, CATV, MATV, networking, computer I/O cables and computer-aided manufacturing applications.

**Table 9: Relative Cost Comparison**

Relative cost comparisons are based on coaxial cable. Chart shows relative shield cost as one component of the total cost of the cable.

These cost ratings may change depending on the physical construction of the cable.

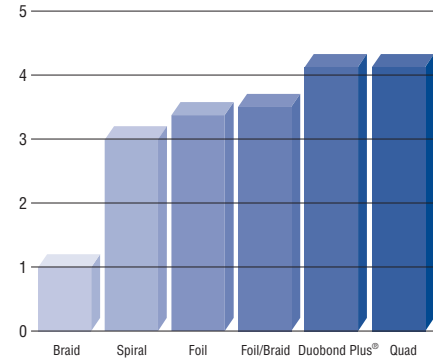

**Table 10: Shield Performance Comparison Chart**

Properties	Cable Shield Ratings*				
	Braid (95% Coverage)	Spiral	Foil	Foil/Braid	Foil/Braid/Foil Duobond Plus®
<b>Frequency: DC</b>					
Capacitive	A	AA	AAA	AAA	AAA
Diffusion	AAA	A	C	AAA	AAA
Diffusion/Inductive	–	–	–	–	–
Diffusion/Inductive/Capacitive	–	–	–	–	–
<b>Frequency: 15 kHz</b>					
Capacitive	A	AA	AAA	AAA	AAA
Diffusion	AAA	B	C	AAA	AAA
Diffusion/Inductive	AA	C	A	AA	AAA
Diffusion/Inductive/Capacitive	–	–	–	–	–
<b>Frequency: 10 MHz to 1000 MHz</b>					
Capacitive	A	AA	AAA	AAA	AAA
Diffusion	–	–	–	–	–
Diffusion/Inductive	B	C	A	AA	AAA
Diffusion/Inductive/Capacitive	B	C	A	AA	AAA

\* Although ratings shown in table 10 are based on shielded coaxial cable test results, these ratings also pertain to shielded multi-conductor and flat cable where shield types are available.

Note: Shield effectiveness decreases as frequency increases. Therefore, ratings in one frequency category do not imply equal shield effectiveness in other frequency categories.

Shield Rating Key	
AAA	Best
AA	Better
A	Good
B	Functional
C	Unsatisfactory
–	Not applicable



### Metric Conversions

Table 14: Conductor Size Equivalents (Square Millimeters/Square Inches/Circular Mils/AWG)

mm <sup>2</sup>	sq. in.	Circular mils	AWG	mm <sup>2</sup>	sq. in.	Circular mils	AWG	mm <sup>2</sup>	sq. in.	Circular mils	AWG
1000	1.550	1974000		55	0.0853	108570		5.00	0.00775	9870	
975	1.511	1924700		—	—	105600	1/0	4.75	0.00736	9377	
950	1.472	1875300		50	0.0775	98700		4.50	0.00698	8883	
925	1.434	1826000		45	0.0698	88830		4.25	0.00659	8390	
900	1.395	1776600		—	—	83690	1	—	—	8230	11
875	1.356	1727300		40	0.0620	78960		4.00	0.00620	7896	
850	1.317	1677900		35	0.0542	69090		3.75	0.00581	7403	
825	1.279	1628600		—	—	66360	2	3.50	0.00542	6909	
800	1.240	1579200		30	0.0465	59220		—	—	6530	12
775	1.201	1529900		—	—	52620	3	3.25	0.00504	6416	
750	1.163	1480500		25	0.0388	49350		3.00	0.00465	5922	
725	1.124	1431200		—	—	41740	4	2.75	0.00426	5429	
700	1.085	1381800		20.0	0.0310	39480		2.63	—	5180	13
675	1.046	1332500		19.5	0.0302	38490		2.50	0.00388	4935	
650	1.008	1283100		19.0	0.0294	37510		2.25	0.00349	4422	
625	0.969	1233800		18.5	0.0287	36520		—	—	4110	14
600	0.930	1184400		18.0	0.0279	35530		2.00	0.00310	3948	
575	0.891	1135100		17.5	0.0271	34550		1.75	0.00271	3455	
550	0.853	1085700	1000 MCM	17.0	0.0264	33560		1.65	—	3260	15
525	0.814	1036400		—	—	33090	5	1.50	0.00233	2961	
500	0.775	987000		16.5	0.0256	32560		—	—	2580	16
475	0.736	937700		16.0	0.0248	31580		1.25	0.00194	2468	
450	0.698	888300		15.5	0.0240	30600	6	—	—	2050	17
425	0.659	839000		15.0	0.0233	29610		1.00	0.00155	1974	
400	0.620	789600	750 MCM	14.5	0.0225	28620		0.90	0.00140	1777	
375	0.581	740300		14.0	0.0217	27640		—	—	1620	18
350	0.542	690900		13.5	0.0209	26650		0.75	0.00116	1481	
325	0.504	641600	600 MCM	—	—	26420		0.70	0.00109	1382	
300	0.465	592200		13.0	0.0201	25660		0.65	—	1290	19
275	0.426	542900	500 MCM	12.5	0.0194	24680		0.60	0.00093	1184	
250	0.388	493500		12.0	0.0186	23690		—	—	1029	20
225	0.349	444200	350 MCM	11.5	0.0178	22700		0.50	0.000775	987	
200	0.310	394800		11.0	0.0171	21710					
185	—	—		—	—	20820	7				
175	0.271	345500	300 MCM	10.5	0.0163	20730					
150	0.233	296100		10.0	0.0155	19740					
125	0.1938	246800		9.5	0.01472	18753					
120	—	211600	4/0	9.0	0.01395	17766					
100	0.1550	197400		8.5	0.01317	16779					
95	0.1472	187530		—	—	16510	8				
90	0.1395	177660		8.0	0.01240	15792					
—	—	167800	3/0	7.7	0.01163	14805					
85	0.1317	167790		7.0	0.01085	13818					
80	0.1240	157920		—	—	13090	9				
75	0.1163	148050		6.5	0.01008	12831					
70	0.1085	138180		6.0	0.00930	11844					
—	—	133100	2/0	5.5	0.00853	10857					
65	0.1008	128310		—	—	10380	10				
60	0.0930	118440									

To Convert:	Multiply by:
Inches to millimeters	25.4
Millimeters to inches	0.03937

# Belden Color Code Charts

## Color Code Chart 1

Cond.	Color
1	Black
2	White
3	Red
4	Green
5	Brown
6	Blue
7	Orange
8	Yellow
9	Purple
10	Grey
11	Pink
12	Tan

18 gage conductors in cables 8446 through 8449 are black and white.

## Color Code Chart 2 and 2R – ICEA (Insulated Cable Engineers Association) Standard\*

Cond.	Color
1	Black
2	White
3	Red
4	Green
5	Brown
6	Blue
7	White/Black Stripe
8	Red/Black Stripe
9	Green/Black Stripe
10	Orange/Black Stripe
11	Blue/Black Stripe
12	Black/White Stripe
13	Red/White Stripe
14	Green/White Stripe
15	Blue/White Stripe
16	Black/Red Stripe
17	White/Red Stripe

Cond.	Color
18	Orange/Red Stripe
19	Blue/Red Stripe
20	Red/Green Stripe
21	Orange/Green Stripe
22	Black/White/Red
23	White/Black/Red
24	Red/Black/White
25	Green/Black/White
26	Orange/Black/White
27	Blue/Black/White
28	Black/Red/Green
29	White/Red/Green
30	Red/Black/Green
31	Green/Black/Orange
32	Orange/Black/Green
33	Blue/White/Orange
34	Black/White/Orange

Cond.	Color
35	White/Red/Orange
36	Orange/White/Blue
37	White/Red/Blue
38	Black/White/Green
39	White/Black/Green
40	Red/White/Green
41	Green/White/Blue
42	Orange/Red/Green
43	Blue/Red/Green
44	Black/White/Blue
45	White/Black/Blue
46	Red/White/Blue
47	Green/Orange/Red
48	Orange/Red/Blue
49	Blue/Orange/Red
50	Black/Orange/Red

\* 2= Spiral Stripe • 2R= Ring Band Stripping

## Color Code Chart 3 for Paired Cables (Belden Standard)

Cond.	Color
1	Black & Red
2	Black & White
3	Black & Green
4	Black & Blue
5	Black & Yellow
6	Black & Brown
7	Black & Orange
8	Red & White
9	Red & Green
10	Red & Blue

Cond.	Color
11	Red & Yellow
12	Red & Brown
13	Red & Orange
14	Green & White
15	Green & Blue
16	Green & Yellow
17	Green & Brown
18	Green & Orange
19	White & Blue
20	White & Yellow

Cond.	Color
21	White & Brown
22	White & Orange
23	Blue & Yellow
24	Blue & Brown
25	Blue & Orange
26	Brown & Yellow
27	Brown & Orange
28	Orange & Yellow
29	Purple & Orange
30	Purple & Red

Cond.	Color
31	Purple & White
32	Purple & Green
33	Purple & Blue
34	Purple & Yellow
35	Purple & Brown
36	Purple & Black
37	Grey & White

## Color Code Chart 4 for Paired Cables

Pair No.	Color Combination
1	White & Blue
2	White & Orange
3	White & Green
4	White & Brown
5	White & Grey
6	Red & Blue
7	Red & Orange

Pair No.	Color Combination
8	Red & Green
9	Red & Brown
10	Red & Grey
11	Black & Blue
12	Black & Orange
13	Black & Green
14	Black & Brown

Pair No.	Color Combination
15	Black & Grey
16	Yellow & Blue
17	Yellow & Orange
18	Yellow & Green
19	Yellow & Brown
20	Yellow & Grey
21	Purple & Blue

Pair No.	Color Combination
22	Purple & Orange
23	Purple & Green
24	Purple & Brown
25	Purple & Grey

## Color Code Chart 5 for Paired Cables (Western Electric Standard)

Pair No.	Color Combination
1	White/Blue Stripe & Blue/White Stripe
2	White/Orange Stripe & Orange/White Stripe
3	White/Green Stripe & Green/White Stripe
4	White/Brown Stripe & Brown/White Stripe
5	White/Grey Stripe & Grey/White Stripe
6	Red/Blue Stripe & Blue/Red Stripe
7	Red/Orange Stripe & Orange/Red Stripe

Pair No.	Color Combination
8	Red/Green Stripe & Green/Red Stripe
9	Red/Brown Stripe & Brown/Red Stripe
10	Red/Grey Stripe & Grey/Red Stripe
11	Black/Blue Stripe & Blue/Black Stripe
12	Black/Orange Stripe & Orange/Black Stripe
13	Black/Green Stripe & Green/Black Stripe
14	Black/Brown Stripe & Brown/Black Stripe

Pair No.	Color Combination
15	Black/Grey Stripe & Grey/Black Stripe
16	Yellow/Blue Stripe & Blue/Yellow Stripe
17	Yellow/Orange Stripe & Orange/Yellow Stripe
18	Yellow/Green Stripe & Green/Yellow Stripe
19	Yellow/Brown Stripe & Brown/Yellow Stripe
20	Yellow/Grey Stripe & Grey/Yellow Stripe
21	Purple/Blue Stripe & Blue/Purple Stripe

Pair No.	Color Combination
22	Purple/Orange Stripe & Orange/Purple Stripe
23	Purple/Green Stripe & Green/Purple Stripe
24	Purple/Brown Stripe & Brown/Purple Stripe
25	Purple/Grey Stripe & Grey/Purple Stripe

## Belden Color Code Charts

### Color Code Chart 6

Position No.	Color
1	Brown
2	Red
3	Orange
4	Yellow
5	Green
6	Blue
7	Purple
8	Grey
9	White
10	White/Black
11	White/Brown
12	White/Red
13	White/Orange
14	White/Yellow
15	White/Green
16	White/Blue
17	White/Purple
18	White/Grey
19	White/Black/Brown
20	White/Black/Red
21	White/Black/Orange
22	White/Black/Yellow
23	White/Black/Green
24	White/Black/Blue

### Color Code Chart 7 for Snake Cables

Pair No.	Color Combination
1	Brown
2	Red
3	Orange
4	Yellow
5	Green
6	Blue
7	Purple
8	Grey
9	White
10	Black
11	Tan
12	Pink
13	Grey/Brown Stripe
14	Grey/Red Stripe
15	Grey/Orange Stripe
16	Grey/Yellow Stripe
17	Grey/Green Stripe
18	Grey/Blue Stripe
19	Grey/Purple Stripe
20	Grey/Grey Stripe

Pair No.	Color Combination
21	Grey/White Stripe
22	Grey/Black Stripe
23	Grey/Tan Stripe
24	Grey/Pink Stripe
25	Blue/Brown Stripe
26	Blue/Red Stripe
27	Blue/Orange Stripe
28	Blue/Yellow Stripe
29	Blue/Green Stripe
30	Blue/Blue Stripe
31	Blue/Purple Stripe
32	Blue/Grey Stripe
33	Blue/White Stripe
34	Blue/Black Stripe
35	Blue/Tan Stripe
36	Blue/Pink Stripe
37	Lime/Brown Stripe
38	Lime/Red Stripe
39	Lime/Orange Stripe
40	Lime/Yellow Stripe

Pair No.	Color Combination
41	Lime/Green Stripe
42	Lime/Blue Stripe
43	Lime/Purple Stripe
44	Lime/Grey Stripe
45	Lime/White Stripe
46	Lime/Black Stripe
47	Lime/Tan Stripe
48	Lime/Pink Stripe
49	Aqua/Brown Stripe
50	Aqua/Red Stripe
51	Aqua/Orange Stripe
52	Aqua/Yellow Stripe
53	Aqua/Green Stripe
54	Aqua/Blue Stripe
55	Aqua/Purple Stripe
56	Aqua/Grey Stripe
57	Aqua/White Stripe
58	Aqua/Black Stripe
59	Aqua/Tan Stripe
60	Aqua/Pink Stripe

### Color Code Chart 8 for DataTwist® Cables (Modified Western Electric)

Pair No.	Color Combination
1	White/Blue Stripe & Blue
2	White/Orange Stripe & Orange
3	White/Green Stripe & Green
4	White/Brown Stripe & Brown
5	White/Grey Stripe & Grey
6	Red/Blue Stripe & Blue/Red Stripe
7	Red/Orange Stripe & Orange/Red Stripe
8	Red/Green Stripe & Green/Red Stripe

Pair No.	Color Combination
9	Red/Brown Stripe & Brown/Red Stripe
10	Red/Grey Stripe & Grey/Red Stripe
11	Black/Blue Stripe & Blue/Black Stripe
12	Black/Orange Stripe & Orange/Black Stripe
13	Black/Green Stripe & Green/Black Stripe
14	Black/Brown Stripe & Brown/Black Stripe

Pair No.	Color Combination
15	Black/Grey Stripe & Grey/Black Stripe
16	Yellow/Blue Stripe & Blue/Yellow Stripe
17	Yellow/Orange Stripe & Orange/Yellow Stripe
18	Yellow/Green Stripe & Green/Yellow Stripe
19	Yellow/Brown Stripe & Brown/Yellow Stripe
20	Yellow/Grey Stripe & Grey/Yellow Stripe

Pair No.	Color Combination
21	Purple/Blue Stripe & Blue/Purple Stripe
22	Purple/Orange Stripe & Orange/Purple Stripe
23	Purple/Green Stripe & Green/Purple Stripe
24	Purple/Brown Stripe & Brown/Purple Stripe
25	Purple/Grey Stripe & Grey/Purple Stripe

### Color Code Chart 9: IBM RISC System/6000

Cond.	Color
1	White over Blue
2	White over Orange
3	White over Green
4	White over Brown
5	White over Grey
6	White over Red
7	White over Yellow

Pair No.	Color Combination
1	White over Blue & Blue over White
2	White over Orange & Orange over White
3	White over Green & Green over White

### Color Code Chart 10 for Fiber Optics\*

Position No.	Color
1	Blue
2	Orange
3	Green
4	Brown
5	Grey
6	White
7	Red

Position No.	Color
8	Black
9	Yellow
10	Purple
11	Rose
12	Aqua

\* per TIA/EIA 598-A

## Belden Color Code Charts

**Chart 11: VDE 47100**

Core No.	Color	Core No.	Color	Core No.	Color
1	White	22	Brown/Blue	43	Blue/Black
2	Brown	23	White/Red	44	Red/Black
3	Green	24	Brown/Red	45	White/Brown/Black
4	Yellow	25	White/Black	46	Yellow/Green/Black
5	Grey	26	Brown/Black	47	Grey/Pink/Black
6	Pink	27	Grey/Green	48	Red/Blue/Black
7	Blue	28	Yellow/Green	49	White/Green/Black
8	Red	29	Pink/Green	50	Brown/Green/Black
9	Black	30	Yellow/Pink	51	White/Yellow/Black
10	Violet	31	Green/Blue	52	Yellow/Brown/Black
11	Grey/Pink	32	Yellow/Blue	53	White/Grey/Black
12	Red/Blue	33	Green/Red	54	Grey/Brown/Black
13	White/Grey	34	Yellow/Red	55	White/Pink/Black
14	Brown/Green	35	Green/Black	56	Pink/Brown/Black
15	White/Yellow	36	Yellow/Black	57	White/Blue/Black
16	Yellow/Brown	37	Grey/Blue	58	Brown/Blue/Black
17	White/Grey	38	Pink/Blue	59	White/Red/Black
18	Grey/Brown	39	Grey/Red	60	Brown/Red/Black
19	White/Pink	40	Pink/Red	61	Black/White
20	Pink/Brown	41	Grey/Black		
21	White/Blue	42	Pink/Black		

**Chart 12: UNEL 00722**

Core No.	Color
2	Brown, Blue
3	Brown, Blue, Green/Yellow
4	Brown, Black, Blue, Green/Yellow
5	Brown, Blue, Black, Black, Green/Yellow

## Halogen-Free Standards

Our halogen-free cables meet the most important international standards. Moreover Belden selected halogen-free jacketing materials are suitable for outdoor use like direct burial.

In comparison to products containing halogens (like PVC), these halogen-free materials offers considerable advantages in case of a fire:

- Less impairment to vision
- Minimal toxic gases
- No release of highly caustic acids
- More safety for man, nature and materials.

Belden's halogen-free cables are both FRNC (= Flame-Retardant, Non-Corrosive ) and LSNH (= Low-Smoke, Non-Halogen).

In the event of a fire, low halogen cables can burn extremely fiercely. In addition, a forced air flow intended to cool equipment can provide a continuous supply of oxygen, thus "feeding" the fire. Where this air flow has a HVAC function, fire and toxic smoke may be distributed to other parts of the building.

### Beyond Zero Halogen

Where there is a risk of fire and/or smoke being propagated and spread throughout a building, there is an additional risk of corrosive and toxic damage. Recent research has demonstrated that several cables in common use may in fact propagate fire and smoke extremely rapidly. These include cables with a fire rating, including low smoke and low halogen. In a number of actual fires, severe structural damage has occurred.

### Products Tested for Public Safety

It goes without saying that where public safety is concerned, there can be no shortcuts. Safety standards are high to ensure minimum damage to life, property and the environment. When it comes to cables, make sure you specify the best products for safety. So you can be confident of performance and quality – even in the event of a calamity.

Belden cables offer the quality and reliability consistent with your long-term needs. And to ensure top performance. Belden cables are available with extended fire ratings. Belden has developed these cables in response to the industry's growing demand for halogen free cables with acid free, non toxic and low smoke density which are also flame and fire retardant.

The test designation (and its meaning) would be one of the following:

#### IEC 60754-1

The cable must be designed with halogen-free plastics. This has an additional advantage: no formation of toxic gases.

#### IEC 60754-2

This test determines the level of corrosion by combustion of insulation-bedding and sheathing compounds. A minimum of 1000 mg ( $\pm 5$  mg) of insulating or sheathing compound should be heated in a furnace, 500 - 600 mm long, to a temperature of 935°C.

#### IEC 60332-3C (Test on Fire Behavior on Cable Bundles)

The cables should be flamed/torched from a distance of 75 mm by a propane gas burner. The test duration is 20 min. The test is passed if the flames extinguish by themselves and when no part of the samples is affected above a 2.5 m height from the burner.

#### IEC 60332-1

A sample of 600 mm is burnt with a flame of a propane gas burner. The test is passed, if the sample has not burnt or when the flames extinguish by themselves and the affected part of the sample which is located the farthest from the bottom edge of the burner has not reached the opposite edge of the sample.

#### IEC 61034-1

The measurement system (27 m<sup>3</sup> chamber) consists of a light source (a standardized 100 W halogen lamp) and a selenium or silicon photo-electric cell, both installed at a height of 2.15 m. A rectangular tray filled with 1 litre of alcohol provides the fire source. A ventilator ensures an even distribution of smoke. The number of test samples depends on the outer diameter. The light intensity is recorded by a plotter. The test is passed if the level of light transmission is not lower than 60%.

Specification	International IEC	Europe CENELEC	Germany VDE	Switzerland SEV	Spain UNE	Italy CEI	France NF	United Kingdom BS	Others
---------------	-------------------	----------------	-------------	-----------------	-----------	-----------	-----------	-------------------	--------

### Material Properties

Quantity of halogen (halogen-free)	IEC 60754-1	EN 50267-2-1	VDE 0482, Teil 267	TP 20B/3C 3.4.5	UNE EN 50267-2-1	CEI 20-37-2	NFC 20-454	-/-	-/-
Toxicity index (no toxic gases)	IEC 60754-1	EN 50305	-/-	-/-	UNE EN 50267-2-1	CEI 20-37-7	NFC 20-454	-/-	NES 713
Degree of Acidity (no corrosive gases)	IEC 60754-2	EN 50267-2-2	VDE 0482, Teil 267	TP 20B/3C 3.4.4/3.4.5	UNE EN 50267-2-3	-/-	NFC 20-454	BS 6425 Part 2	-/-

### Fire Performance

Fire retardant (no flame propagation)	IEC 60332-3C IEC 60333-3	EN 50265-2-1 (HD405.3)	VDE 0482, Teil 266-2-4	TP 20B/3C 3.4.1.3	UNE 20423-3 UNE 20427	CEI 20-22-3	NFC 32070-C1	BS 4066 Part 3	-/-
Flame retardant	IEC 60332-1	EN 50265-2-1 (HD405.1/2)	VDE 0482, Teil 265-2-1	TP 20B/3C 3.4.1.1	UNE EN 50265-2-1	-/-	-/-	BS 4066 Part 1	-/-
Low smoke density	IEC 61034-1	EN 50268-2-1	VDE 0482, Teil 268	TP 20B/3C 3.4.3	UNE EN 50268	CEI 20-37-5	-/-	BS 7622 Part 1	-/-

## Environmental Regulations and Compliance

### Heavy Metal Free, RoHS and Prop 65

Over the past several years, increased attention has been placed upon the potential environmental impacts of electronic products. Both voluntary and regulatory measures have been taken to address some of these concerns. Already in place are California Proposition 65 and the European Union End-of-Life Vehicle (ELV) and Flame Retardant Directives. Since July 2006 the European Union Restriction on Hazardous Substances (RoHS) Directive is in place and restricts the use of heavy metal substances (Lead, for example) in electronic products. There are also several states and countries currently considering their own legislation on this topic.

The use of materials that are environmentally friendly is of growing concern to Belden, its customers and to the global community since January 2006. Belden is engaged in a world-wide project to integrate into its product designs and supplier requirements a formalized program to restrict the use of these materials. The following list of materials represents examples of substances that Belden is eliminating or reducing in certain applications:

- Asbestos and its compounds
- Cadmium and its compounds
- Chromium VI and its compounds
- Lead and its compounds
- Mercury and its compounds
- Polybrominated biphenyls (PBBs) and their ethers/oxides (PBDEs, PBBEs)
- Di-(2-ethylhexyl)phthalate (DEHP)
- Penta-, Octa-BDE brominated flame retardants

As a result of this project, many of Belden's products are now, heavy metal free and meet the requirements of both RoHS and California Proposition 65. Please consult the Glossary of Terms section, contact Belden customer service or visit [www.belden-emea.com](http://www.belden-emea.com) for more specific product details and current compliance information.

### RoHS Compliance

Unless so marked, cables in this catalog do not contain any of the following restricted substances, as an intentional additive, and is therefore compliant with European Directive 2002/95/EC (RoHS), European Directive 2000/53/EC (ELV), European Directive 2003/11/EC (BFR), European Directive 2002/96/EC (WEEE), and California Proposition 65 Consent Judgement for Wire & Cable Manufacturers [San Francisco Superior Court Nos. 312962 and 320342] (Prop 65).

For customer convenience, Belden products that are in compliance with these directives contain the identification "ROHS" within the text of the jacket surface printing and also an environmentally friendly logo (as shown at right) on package labeling.



Substance	Maximum Concentration*
Lead	0.03%
Mercury	0.10%
Hexavalent Chromium	0.10%
PBB, PBDE**	0.10%
Cadmium	0.01%

\* Per homogeneous material, as trace or contaminate amount.

\*\* Some Belden cables may contain Decabromodiphenyl Oxide/Ether (PBDE) as a flame retardant. This substance is currently exempt from RoHS.

In addition, Belden products do not contain asbestos and its compounds or Di-(2-ethylhexyl)phthalate (DEHP).

This determination is based upon information obtained from sources which Belden believes are reliable, and from random sample testing at the Belden Engineering Center; however, the information is provided without any representation of warranty, expressed or implied, regarding accuracy or correctness. Belden does not specifically run any analysis on our raw materials or end product to measure for these substances.

The information provided in this catalog, and the identification of materials listed as reportable or restricted within the catalog, is correct to the best of Belden's knowledge, information and belief at the date of its publication. The information provided in the catalog is designed only as a general guide for the safe handling, storage, and any other operation of the product itself or the one that it becomes a part of. This catalog is not to be considered a warranty or quality specification. Regulatory information is for guidance purposes only. Product users are responsible for determining the applicability of legislation and regulations based on their individual usage of the product.

## Cable Packaging

Belden, a recognized leader in state-of-the-art packaging design, has introduced a variety of packaging styles and options for the convenience of our customers:

### UnReel®

A wide variety of Belden cable and plenum cable is available in Belden's UnReel cardboard dispenser.

Belden UnReel is a unique packaging/dispensing system developed to save time, cut costs and labor, and eliminate the need for dereeling equipment.

Lightweight and more economical than conventional drums or reels, UnReel dispensers have pre-punched handles for easy, individual transport as well as rectangular boxes for easy pallet delivery and storage. Unreeled cable pays out smoothly and evenly with no kinking, twisting, or backlashing. It also rolls out 60% faster per hour than conventionally packaged cable.

UnReel ships, stores and dispenses in one carton, which – since its introduction – has always been fully recyclable and biodegradable. Look for the letter “U” in the put-up (“length”) description.

### Coil Package

New Generation cables are available in a coil package. These revolutionary coils come in an easy-to handle standard package size so pallet loading is uniform. In addition, the densely packaged coil requires less shelf space, truck space or cage space. In addition, because there is no box and no spool, far less waste and clean-up are required after use.

This is the most tangle-proof package available and, because the wire pulls from the middle you only have to handle the weight of the length of wire between you and the coil. This is a great advantage over the conventional spool where it is necessary to pull the whole weight of the package to get it spinning and, once spinning, the spool does not stop. Often assistance is required to stop for payouts from tangling. With coils, no assistance is required and there is no tangling. In addition, five coils can be stacked and pulled in parallel through their common centre.

### Terms of Use of Master Catalog

#### Use of Information; Disclaimers

Although Belden makes every reasonable effort to ensure their accuracy at the time of this publication, information and specifications described in this catalog are subject to change without notice. The most current product information may be found by accessing our website at [www.belden-emea.com](http://www.belden-emea.com) or contacting Belden Technical Support at +31-77-3875-414.

Belden provides the information and specifications in this catalog on an “AS IS” basis, with no representations or warranties, whether express, statutory or implied. WITH RESPECT TO SUCH INFORMATION AND SPECIFICATIONS, BELDEN DISCLAIMS ALL WARRANTIES OF MERCHANTABILITY, FITNESS FOR INTENDED PURPOSE AND NON-INFRINGEMENT. IT ALSO EXCLUDES ANY EXPRESS OR IMPLIED WARRANTIES ARISING FROM ANY COURSE OF DEALING, USAGE, TRADE PRACTICE OR PERFORMANCE. BELDEN'S SOLE WARRANTIES ARE AS BELDEN MAY PROVIDE IN (AND SUBJECT TO THE TERMS AND LIMITATIONS OF) SEPARATE WARRANTY DOCUMENTATION.

In no event will Belden be liable for any damages (including consequential, indirect, incidental, special, punitive, or exemplary damages) whatsoever, even if Belden has been advised of the possibility of such damages, whether in an action under contract, negligence or any other theory, arising out of or in connection with the use, inability to use, or performance of the information, specifications or products described in this catalog.

#### Conversions

All conversions are from feet to metres and have been rounded off. Amounts invoiced will be for actual lengths delivered.

#### Belden's Terms and Conditions of Sale

All sales of Belden products are subject to Belden's standard terms and conditions of sale.

#### Intellectual Property Protection

All trademarks or registered trademarks mentioned in this catalog are property of their respective owners. The information contained in this catalog is protected by copyright. No part of this catalog may be reproduced by any means without the prior written permission from Belden.

#### U.S. and European Export Laws

The United States and European Export Controls laws prohibit the export of certain technical data and software to certain territories. No content from this catalog may be reproduced or otherwise exported in violation of United States or European Law.